

Chevy C15A Van Lorry with Cab13 assembly C15 frame assembly

**pins on crossbeams into
holes in frame sides**

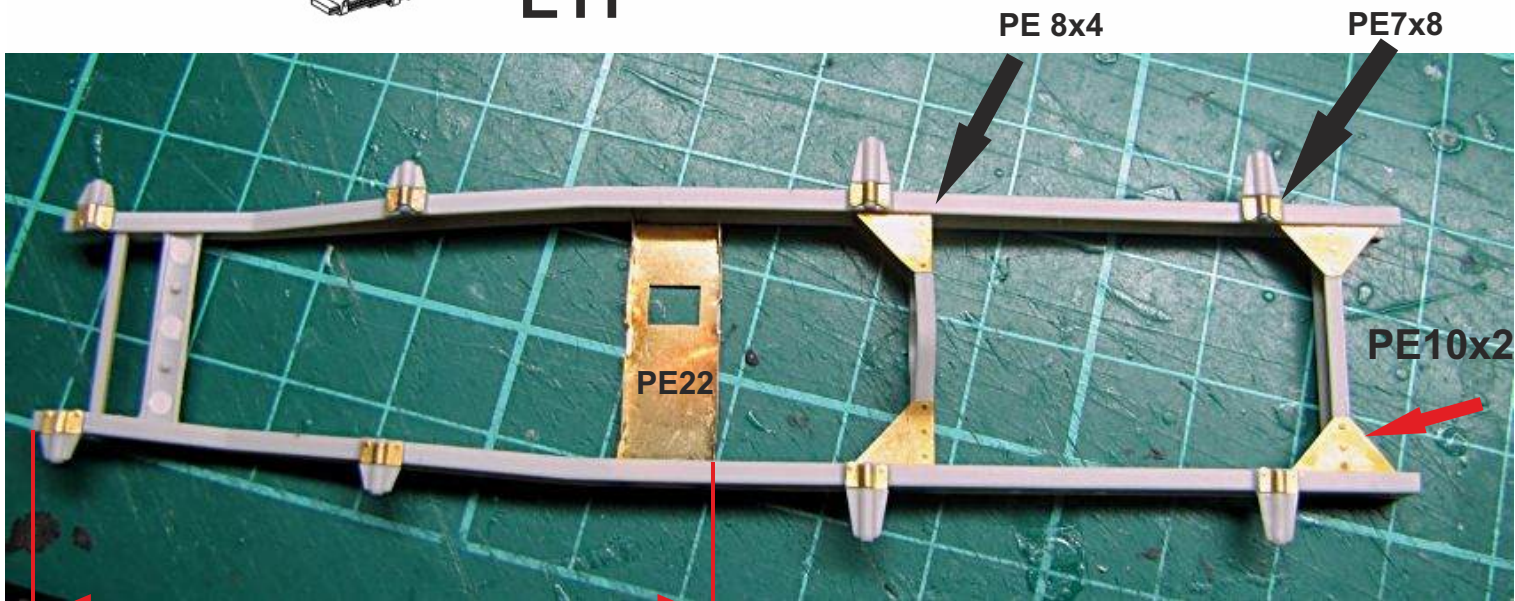

59mm

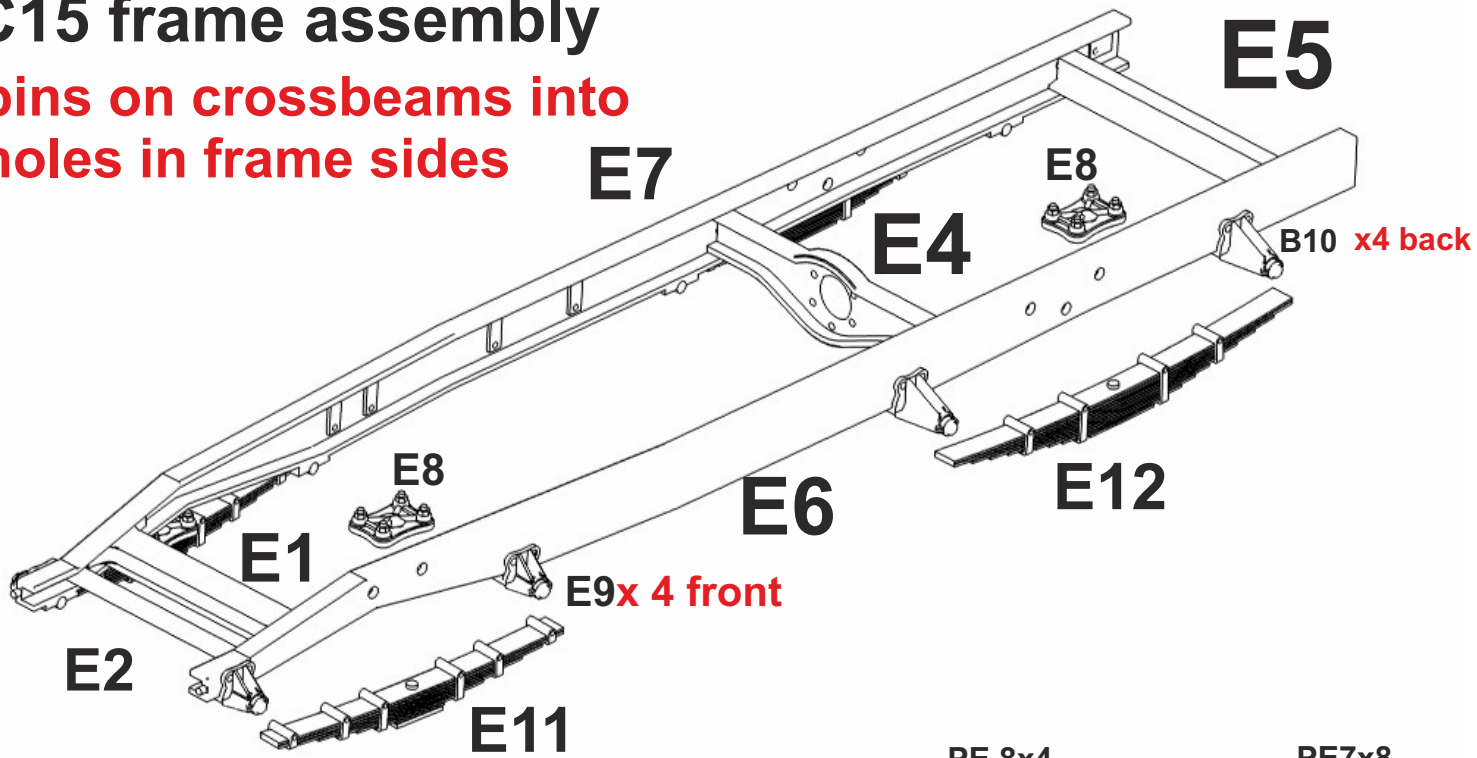
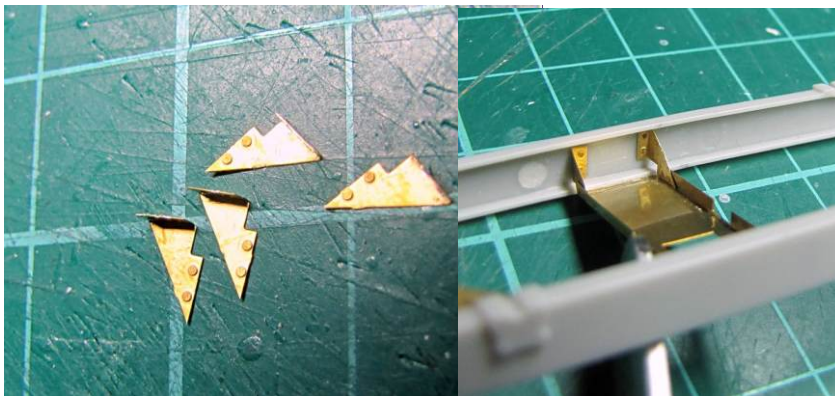

PE23x4

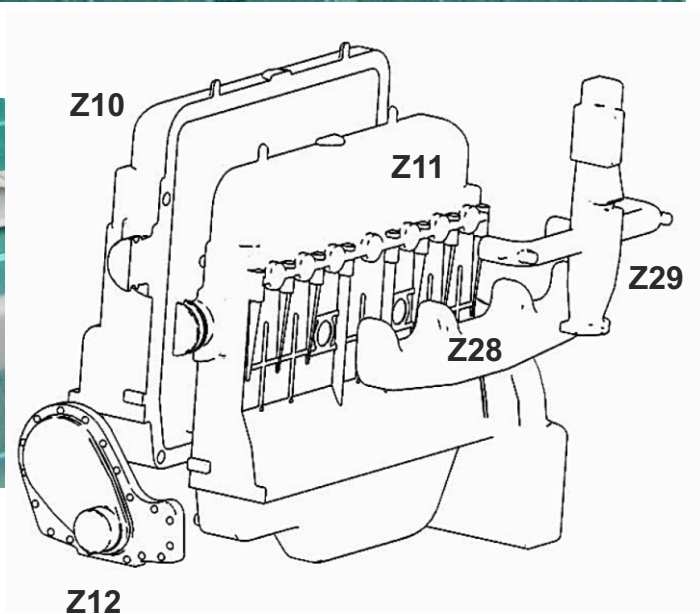

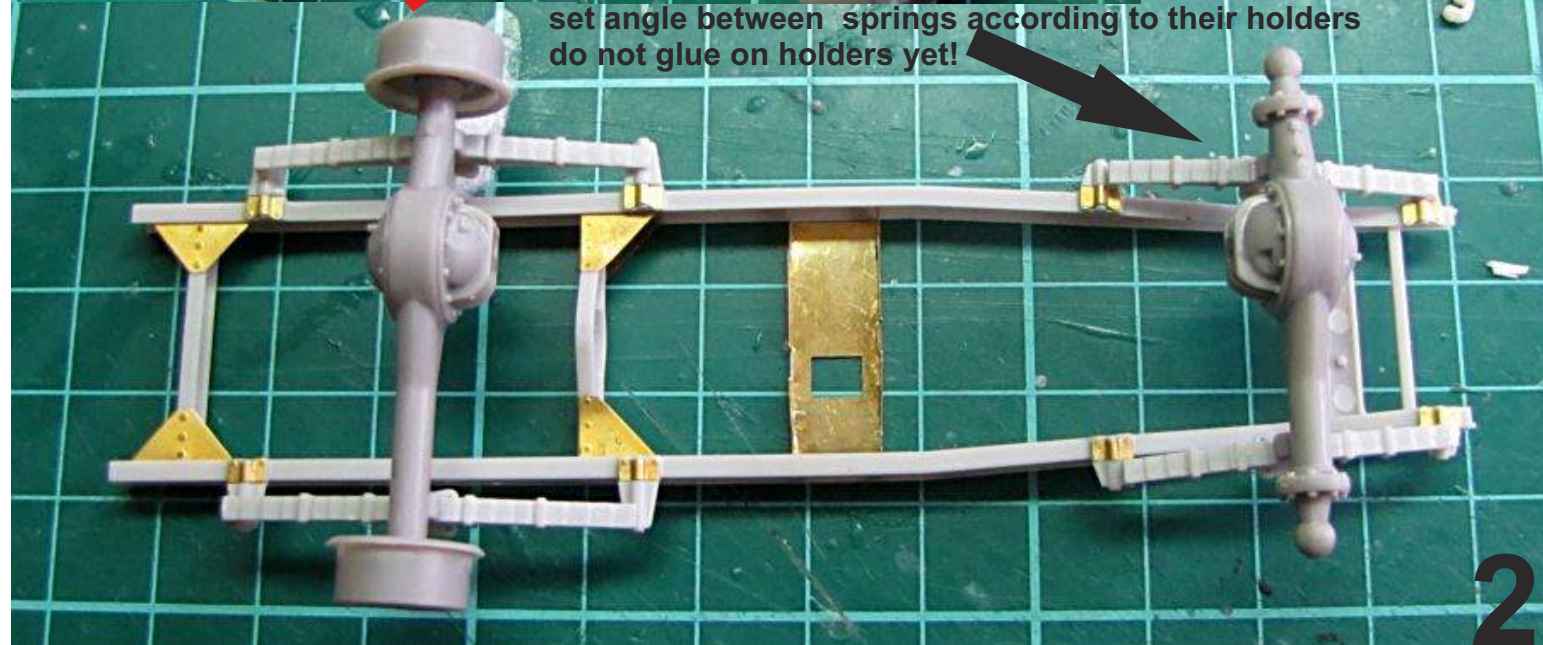
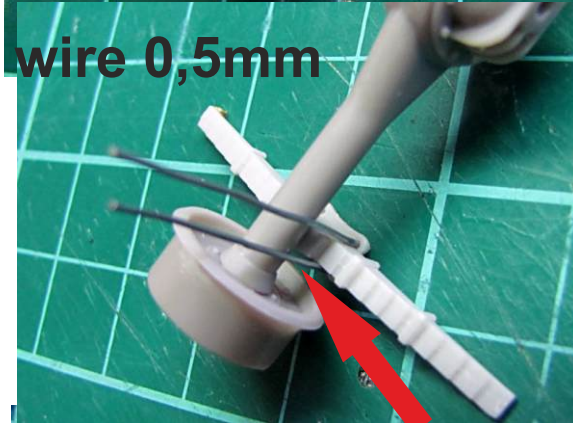
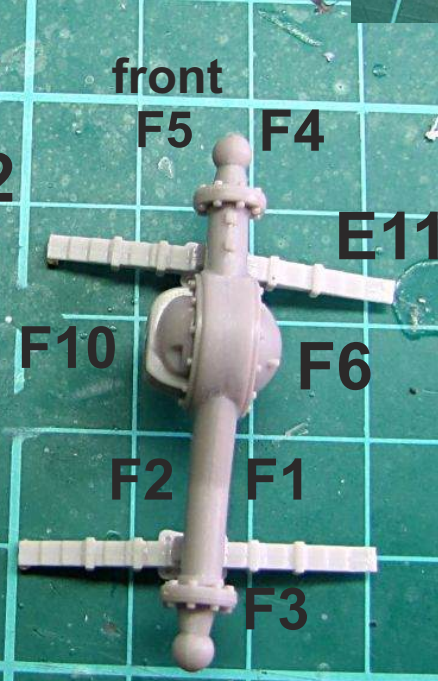
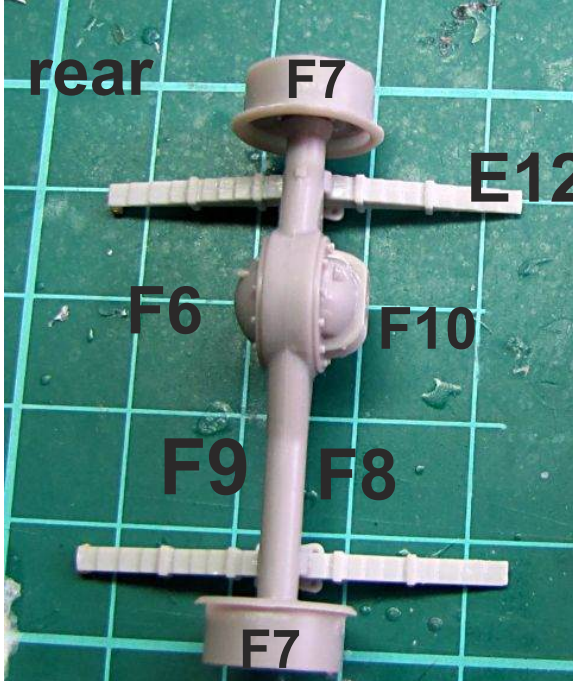
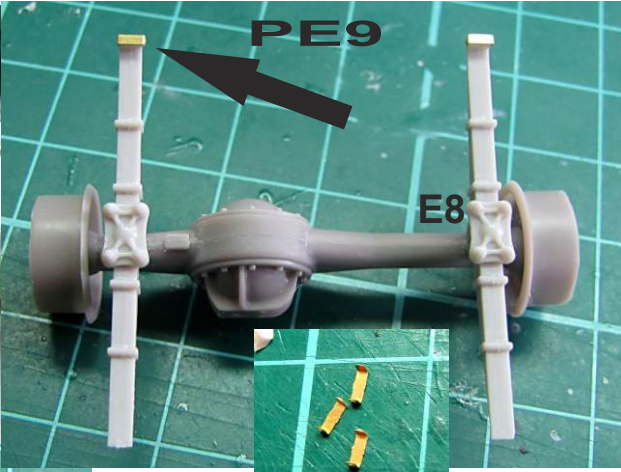
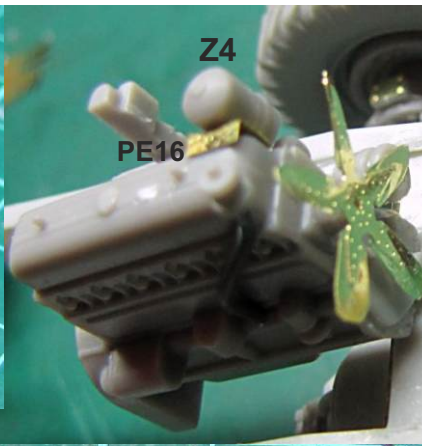
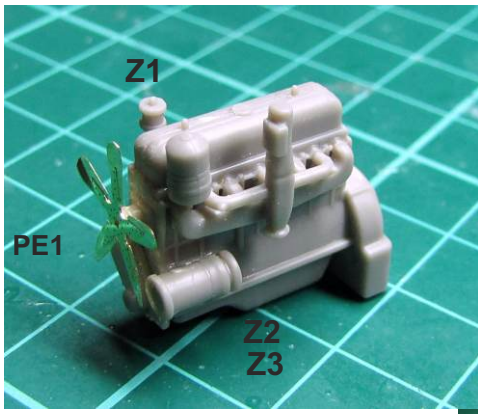

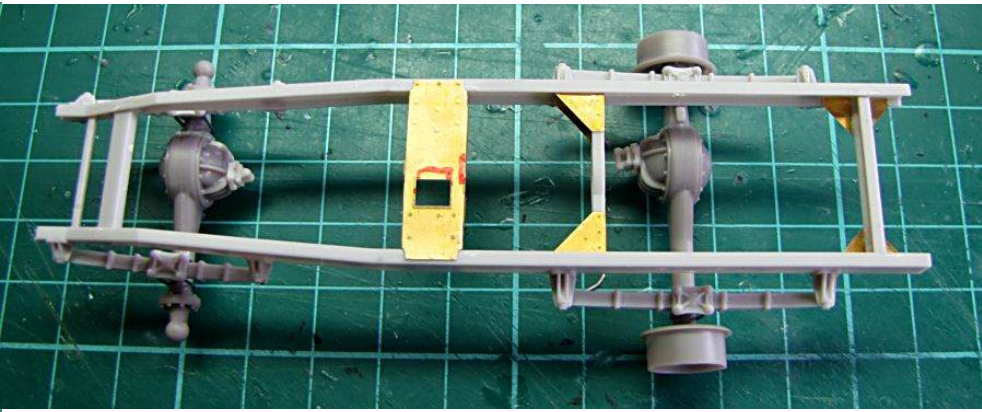

glue axles in position

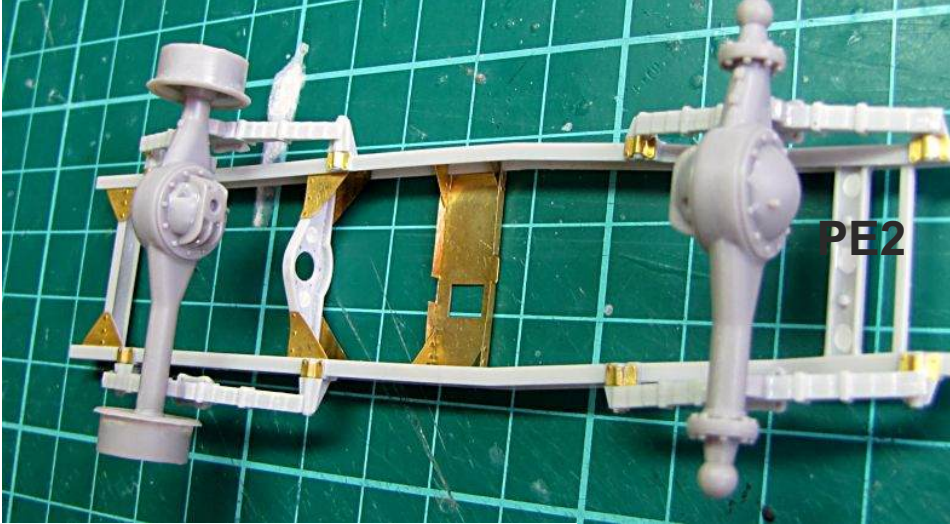

mind direction of tire pattern

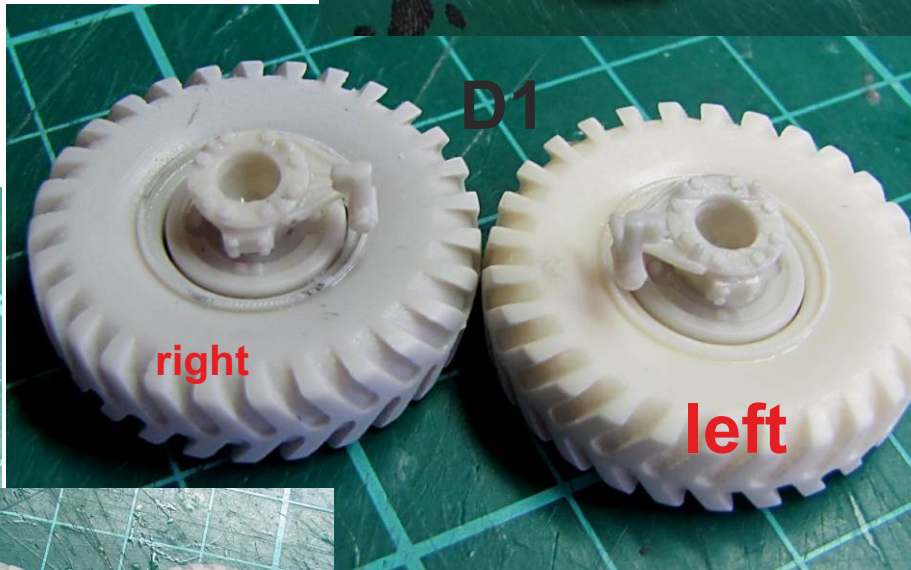
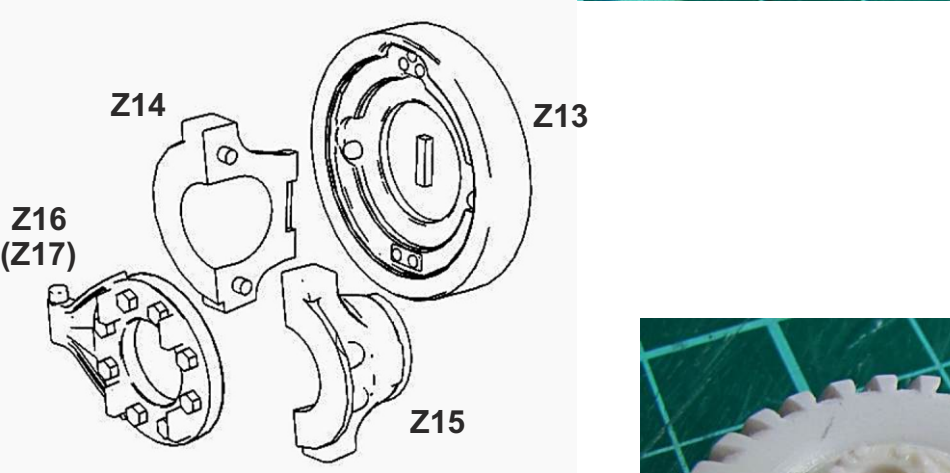

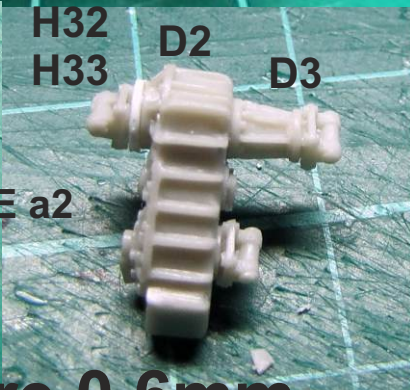
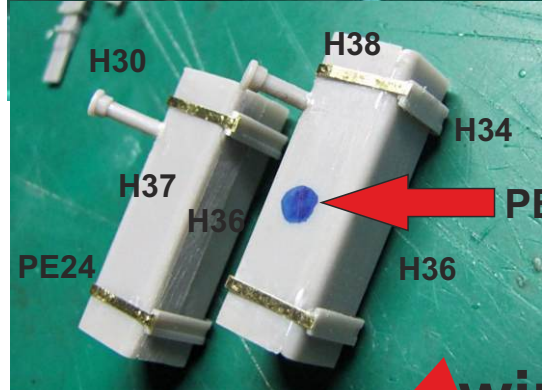
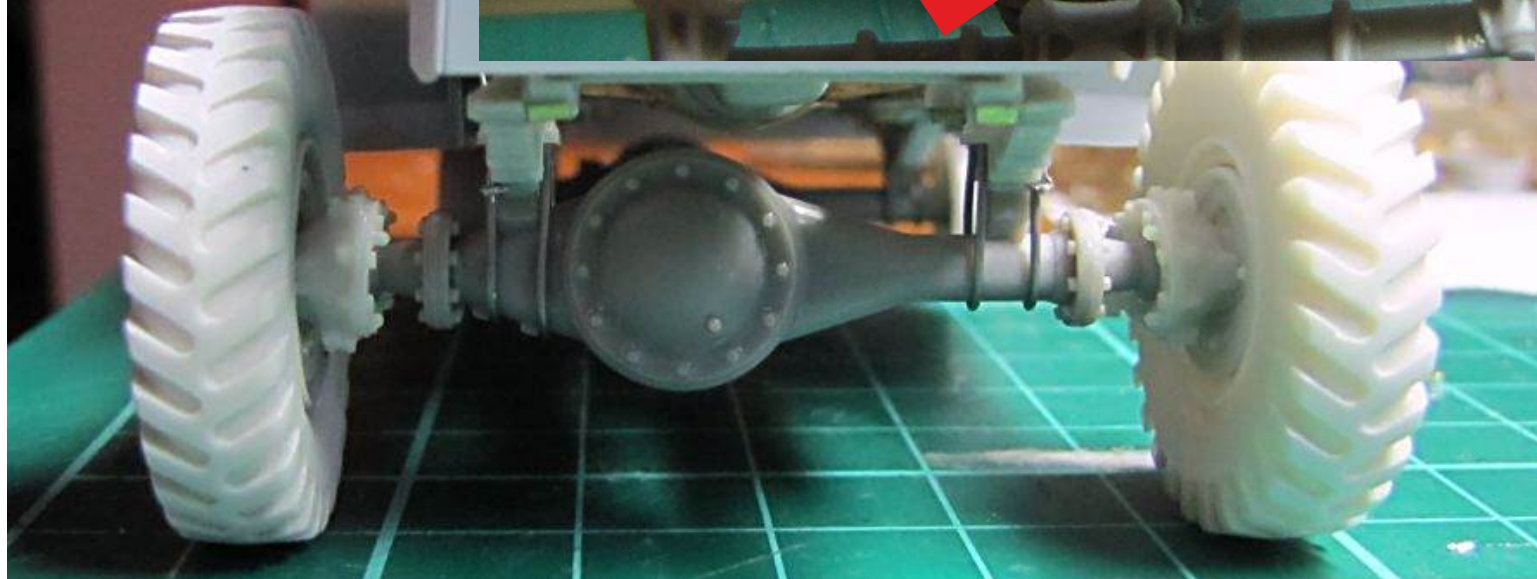
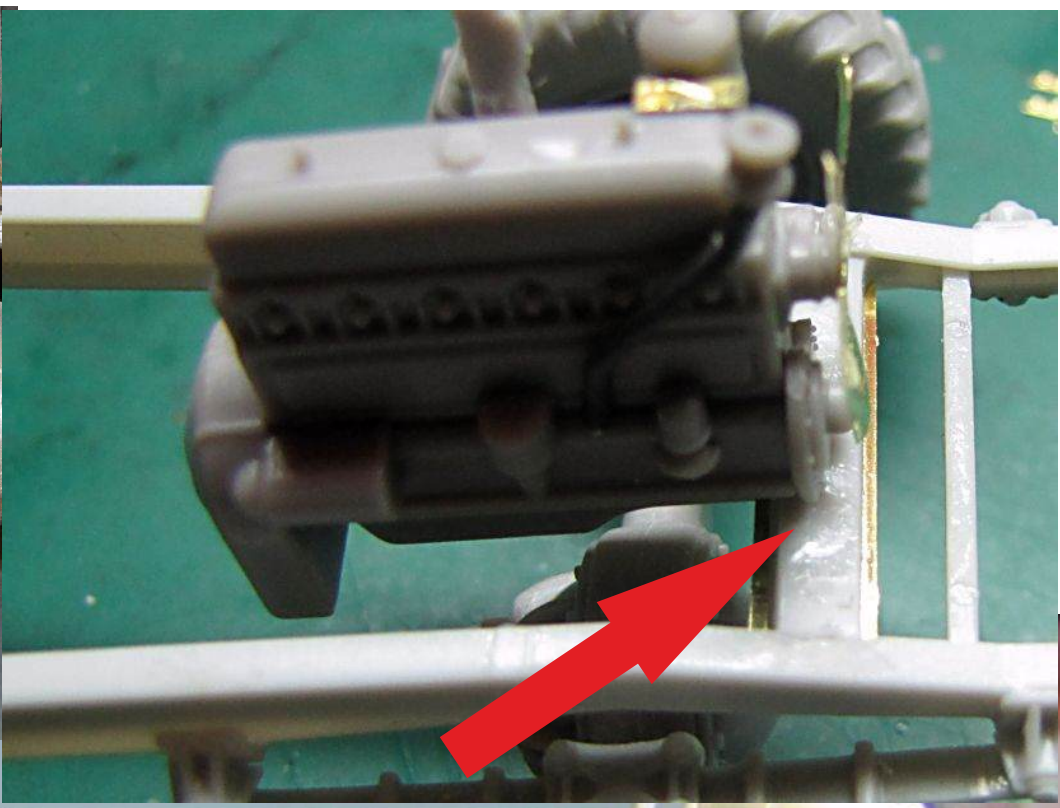

PE11 push rivets from the back assemble D4, then Z8+Z9 and then place D2 in position and secure with C/A glue

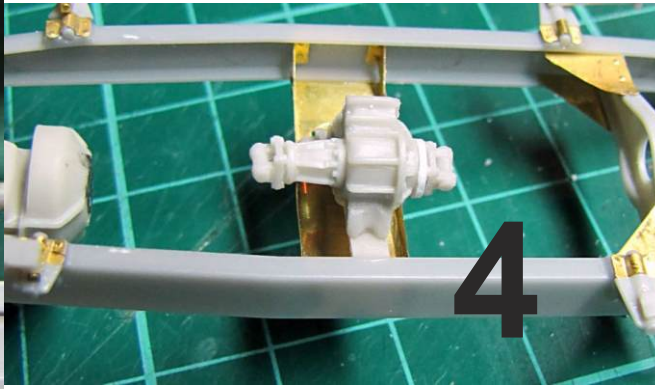
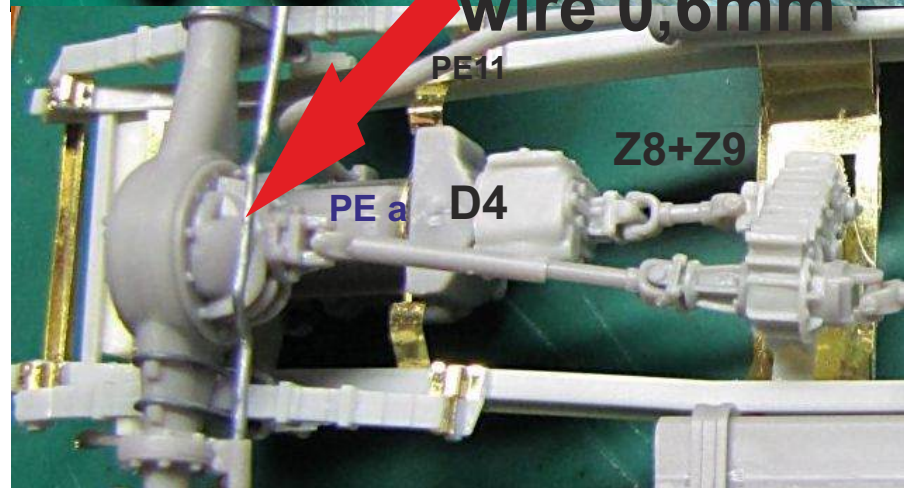

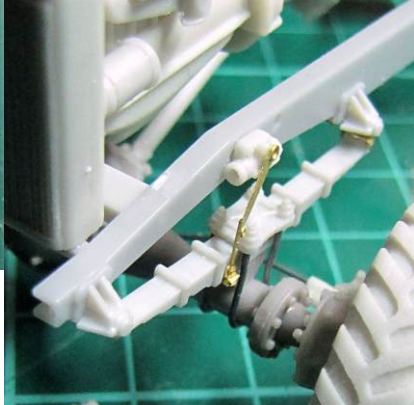
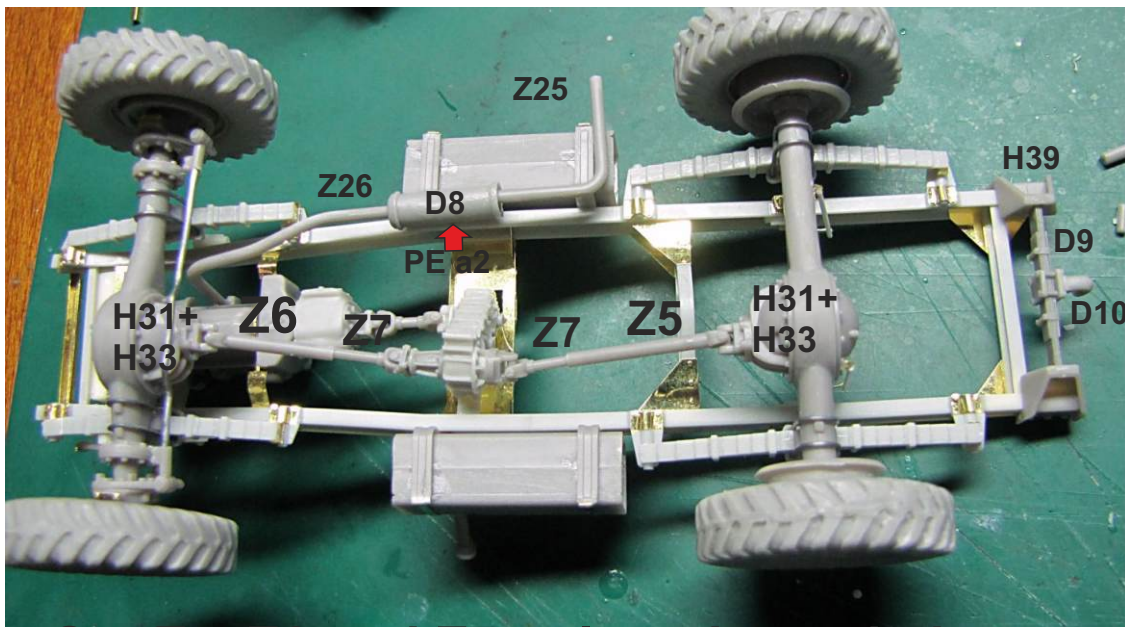

Cut Z5, Z6 and Z7 to length needed

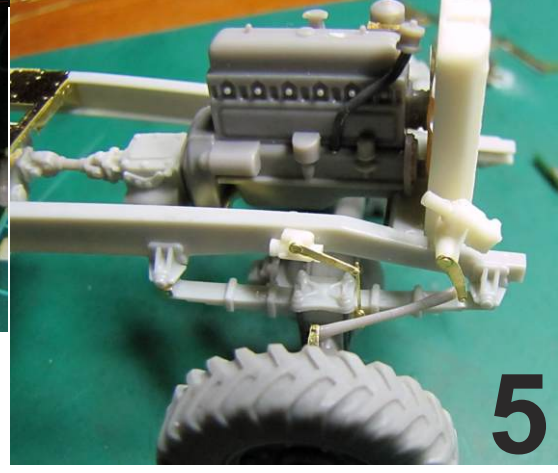
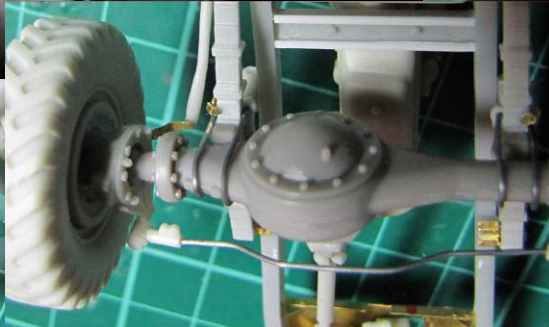
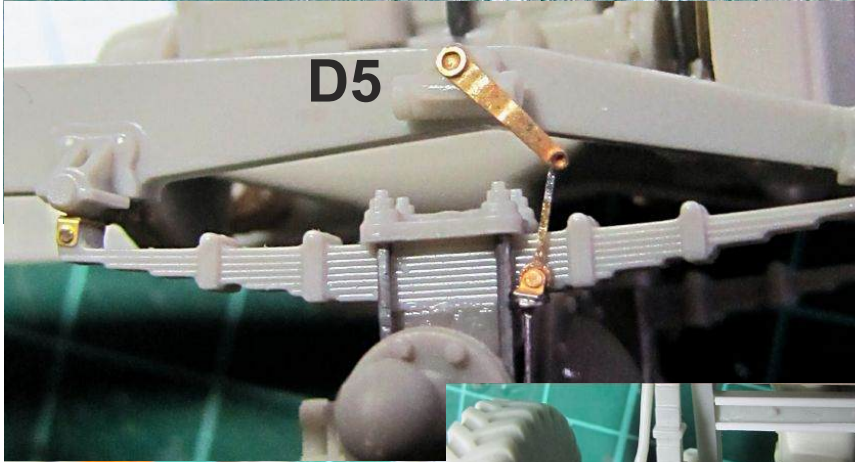
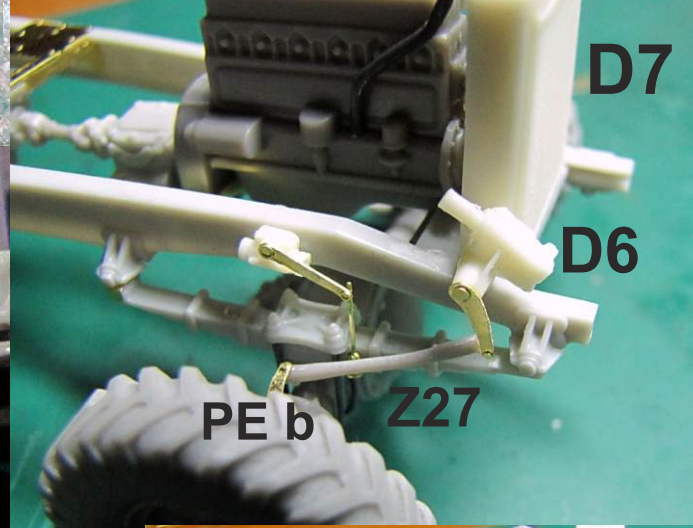
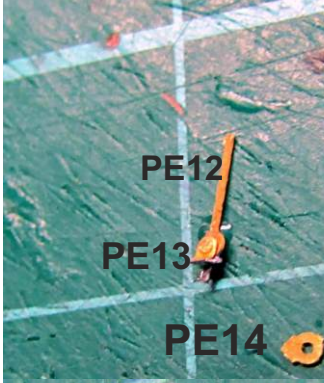

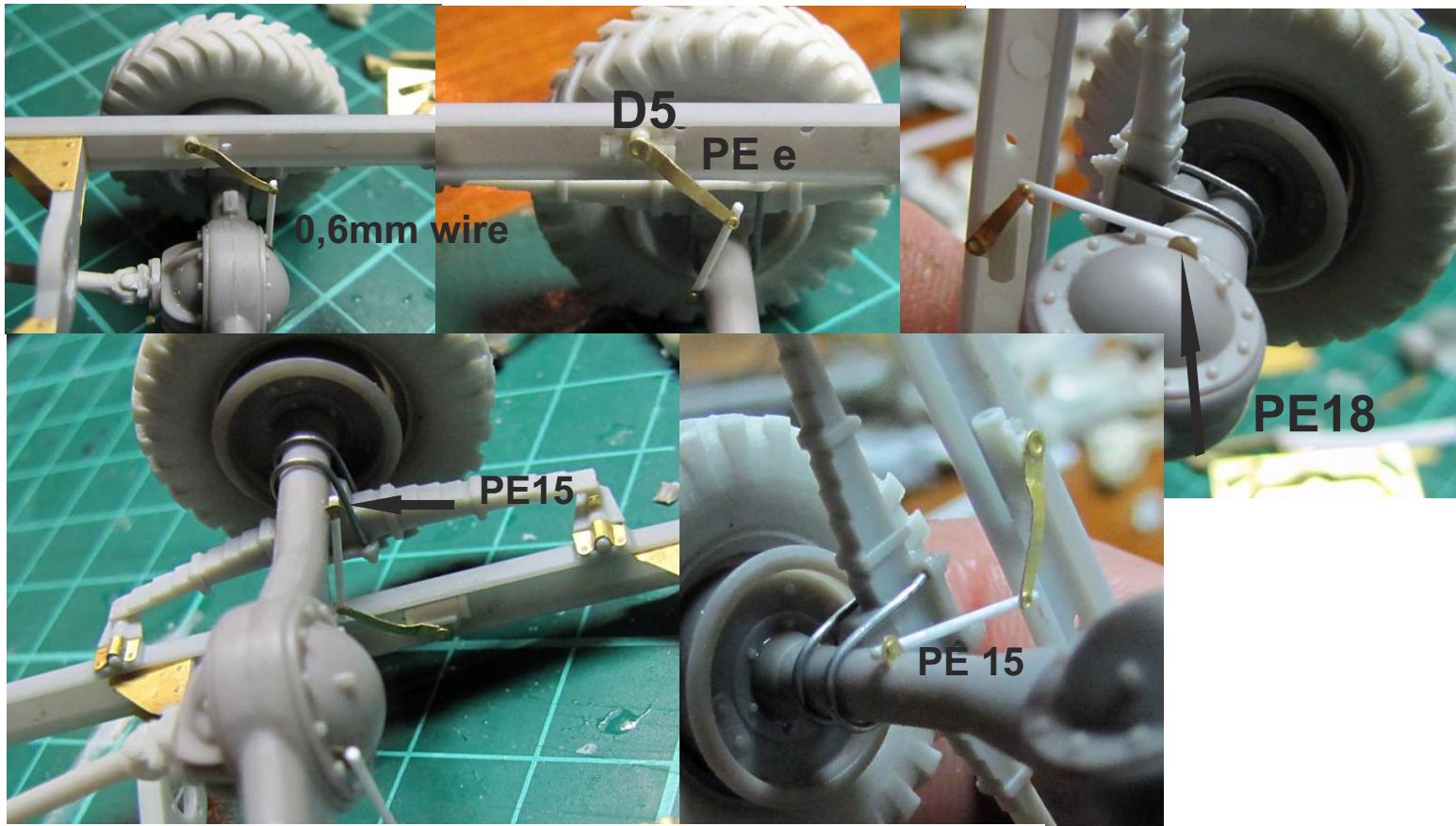

2B1 Body

PE1, PE5, PE7 optional to replace plastic

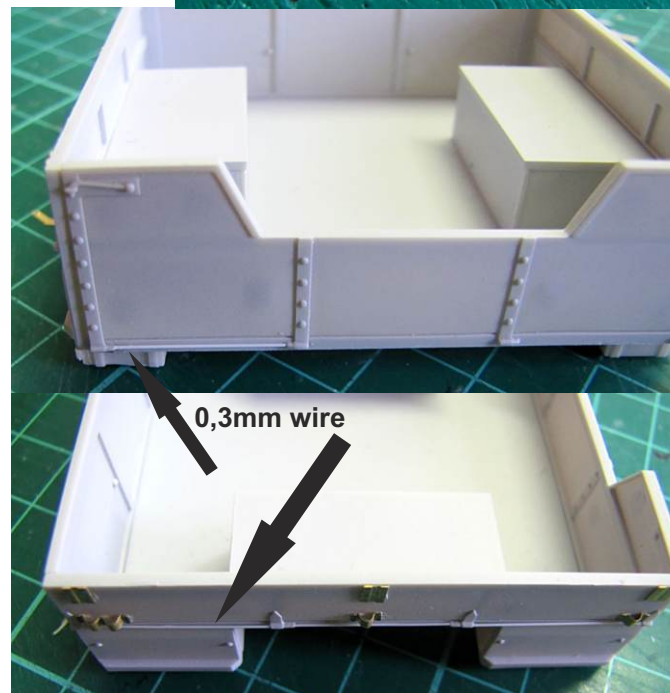
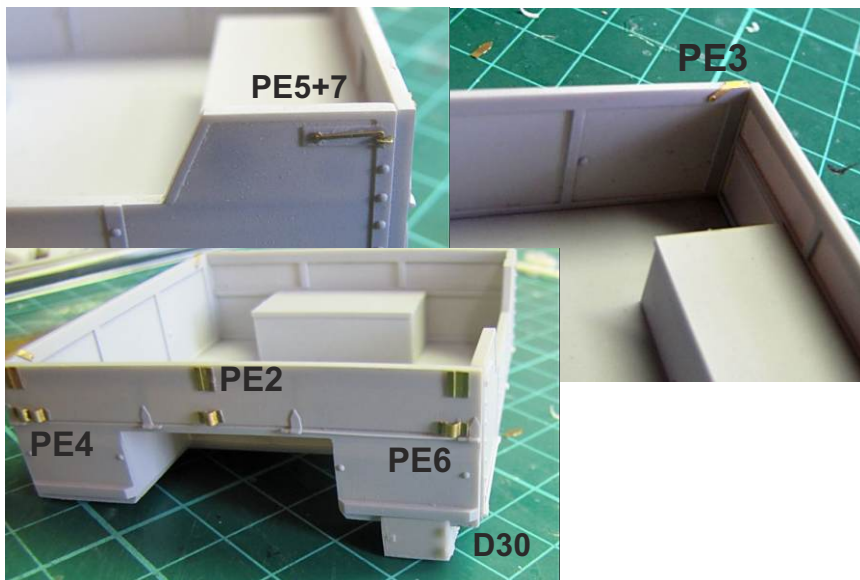
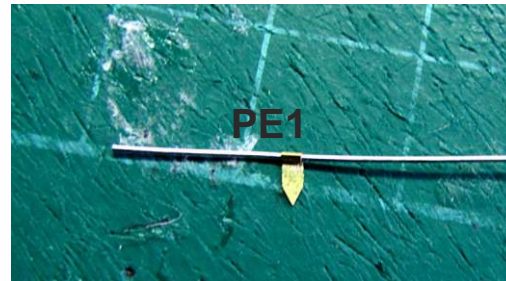
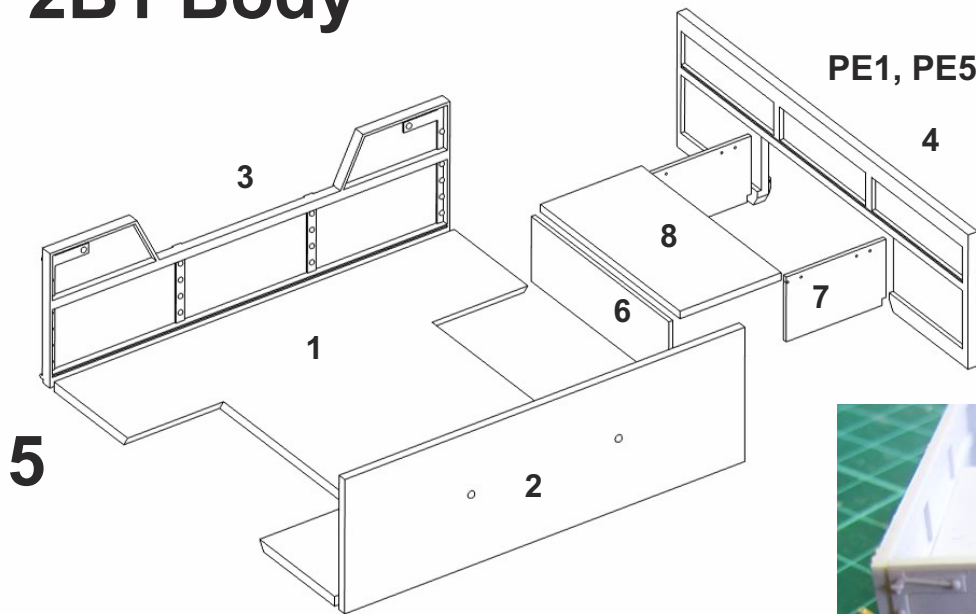

Cab13 assembly

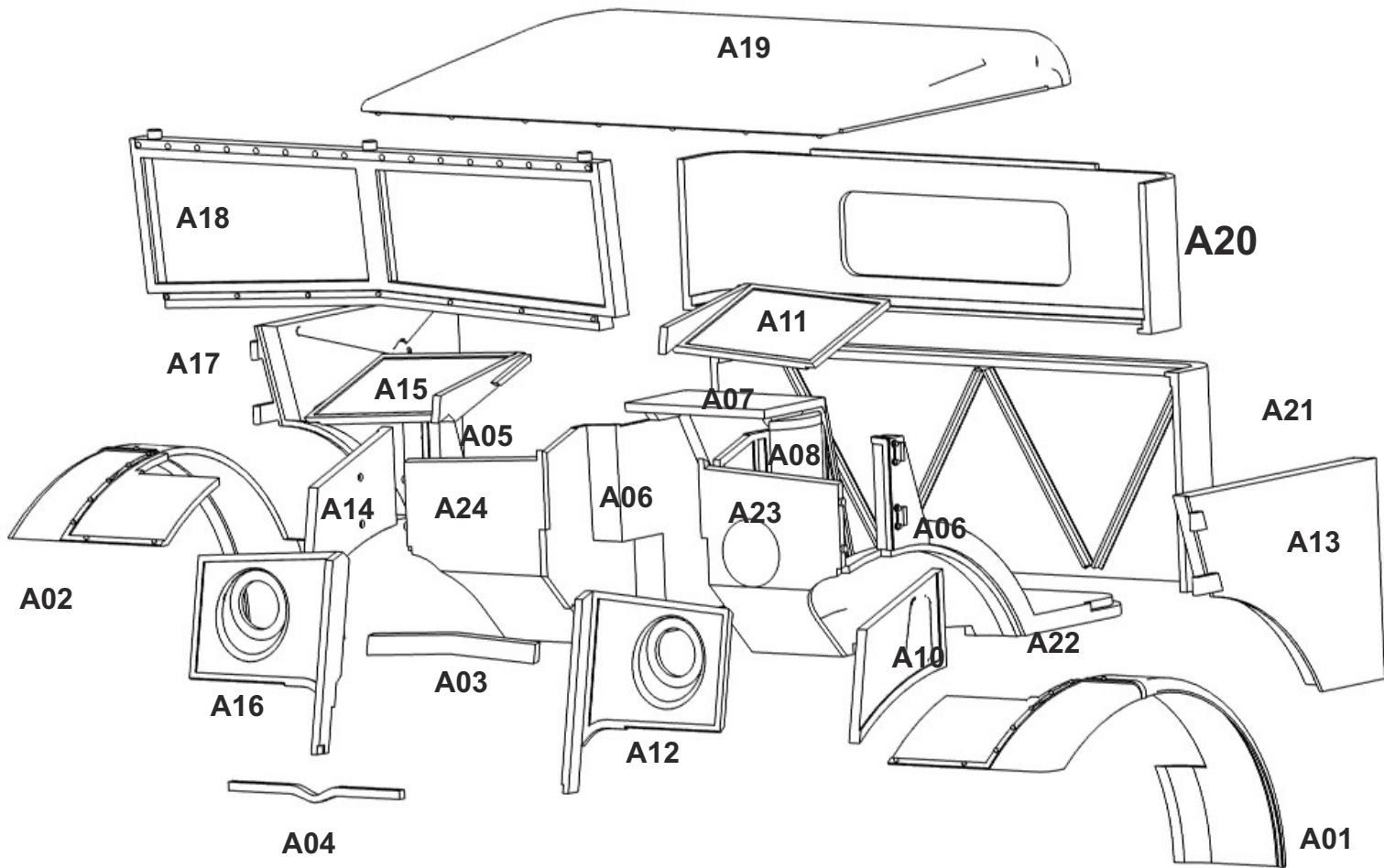

Push rivets out from the back

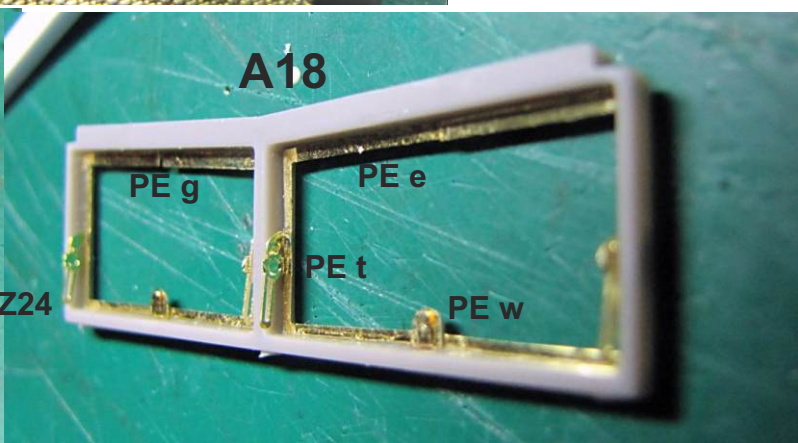
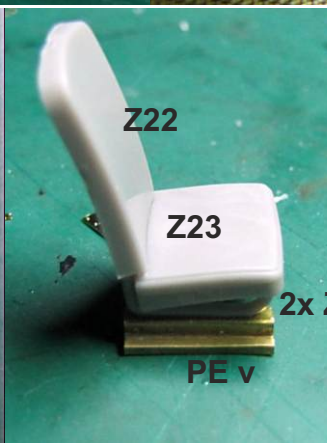
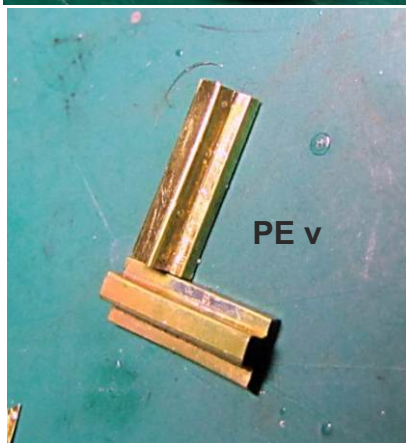
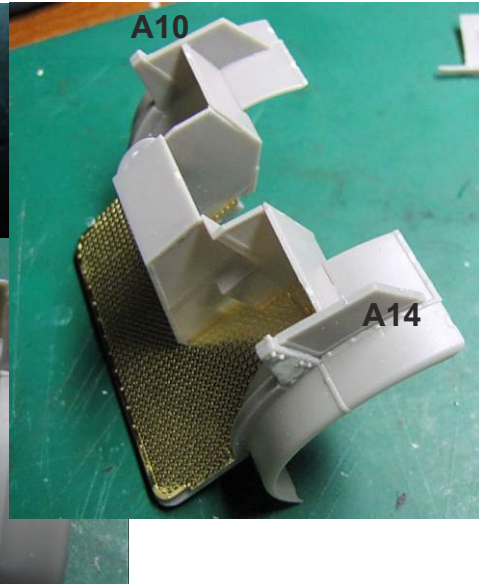
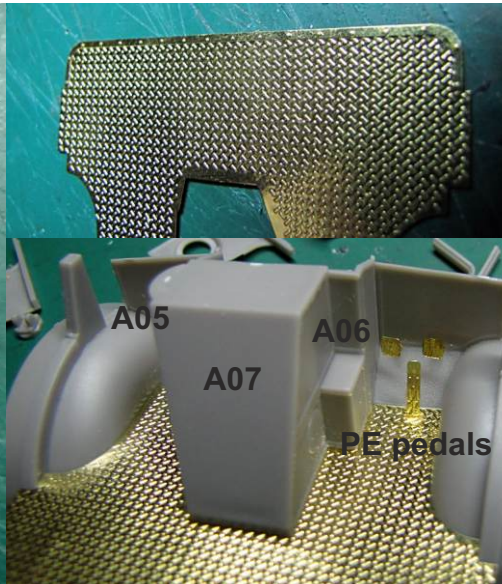
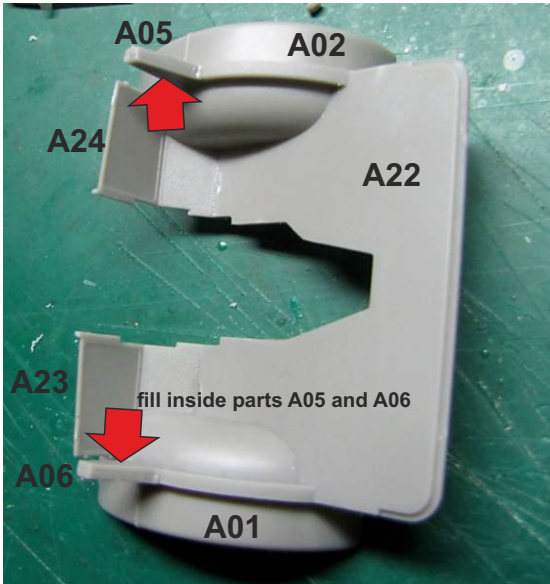

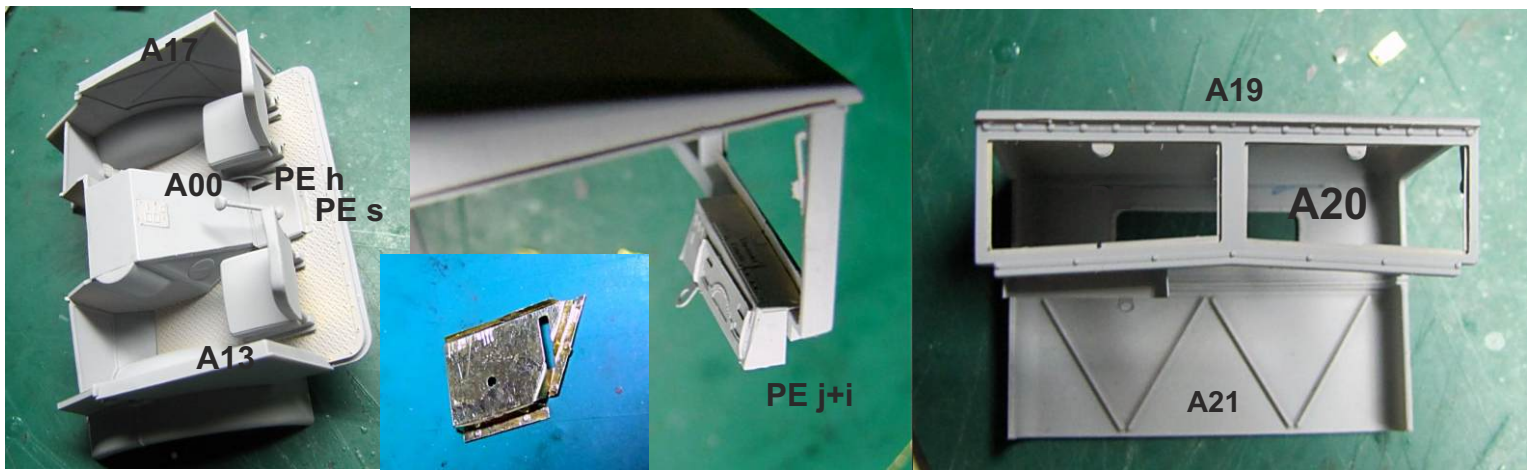

Assemble also steering wheel A29 with 1mm wire before you close cab, cut front windows from clear PS sheet to fit on openings in plastic frames, the assemble PE frames PE d+f (some might prefer to assemble these first and PE e+g after). Assemble clear rear window and both PE frames - inside and outside

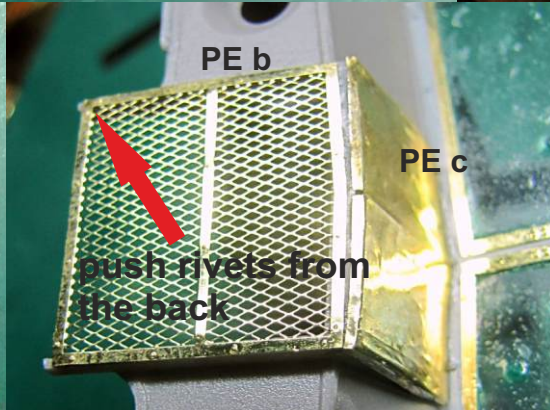
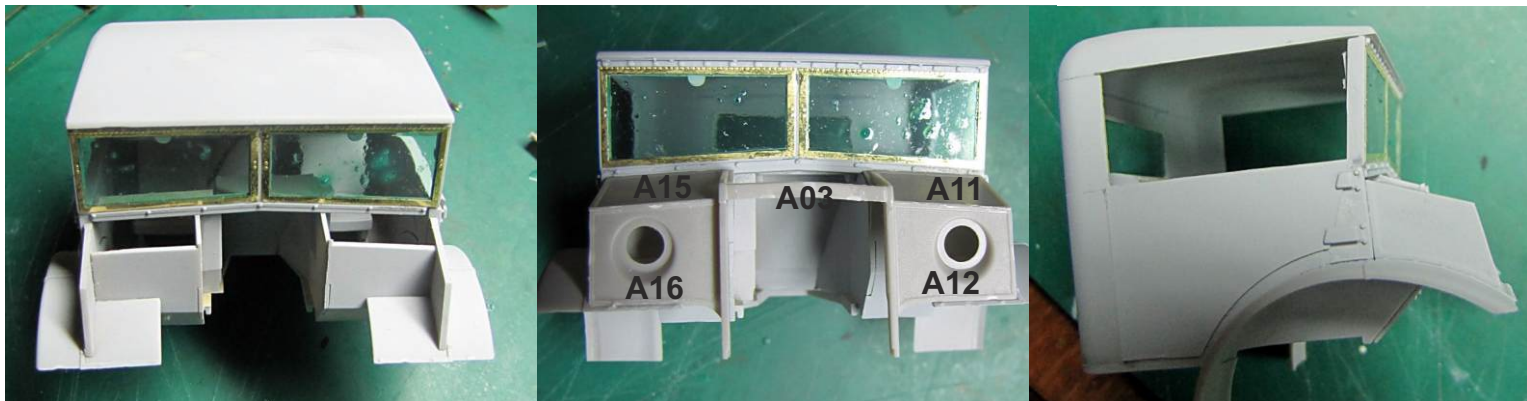

Bonnet cover PE b can be assembled in open position

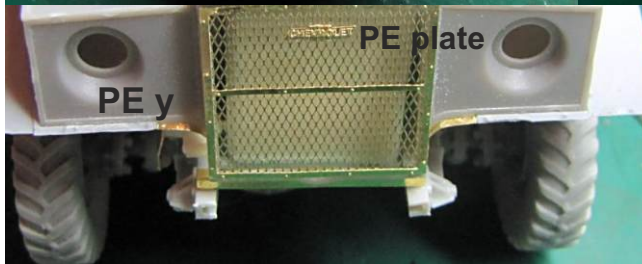
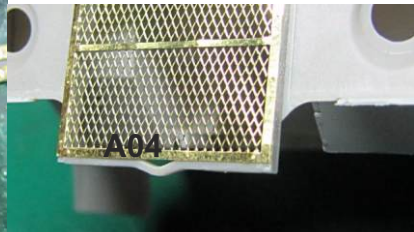

cab should be positioned slightly to the back, just to touch PE22 there

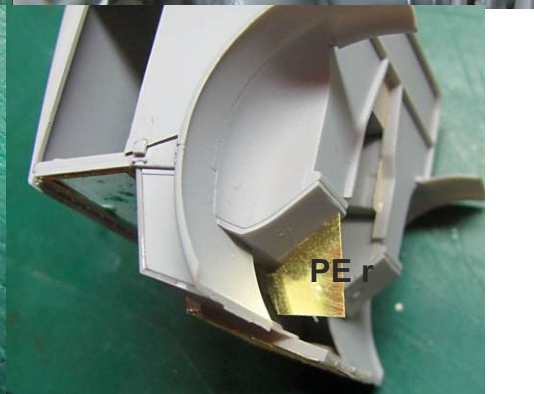
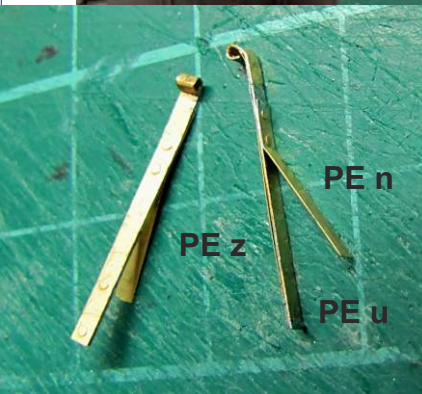
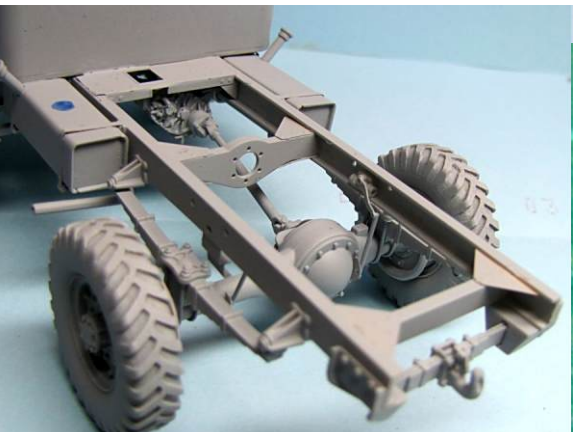
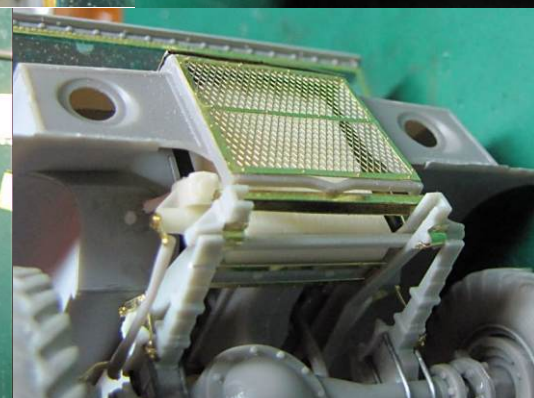

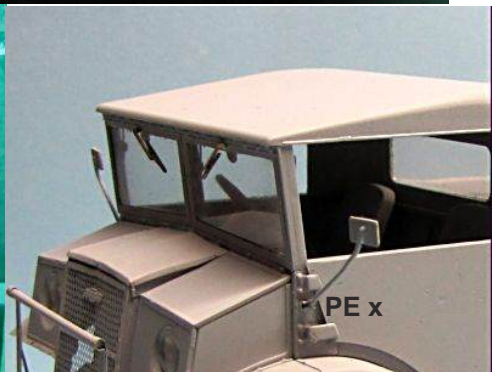
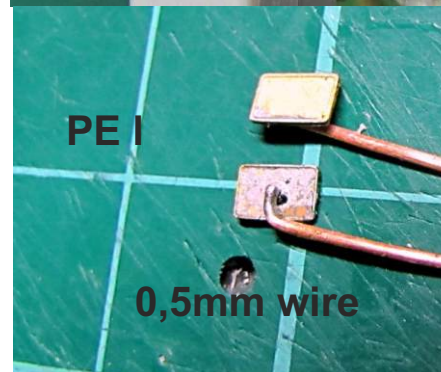
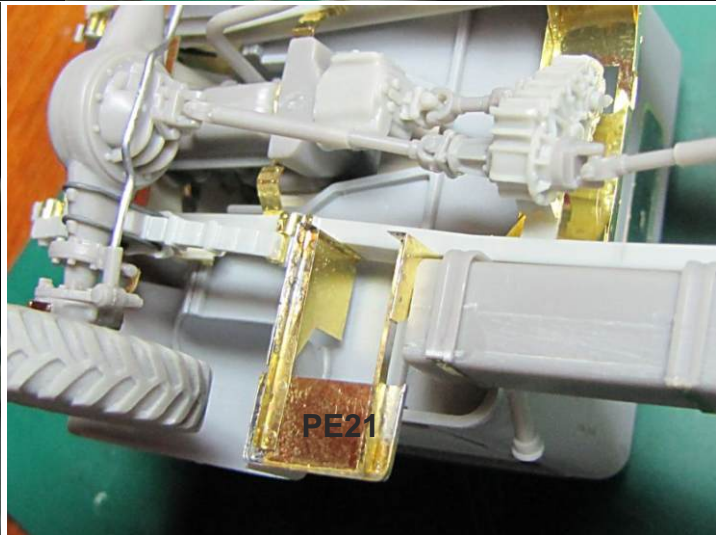
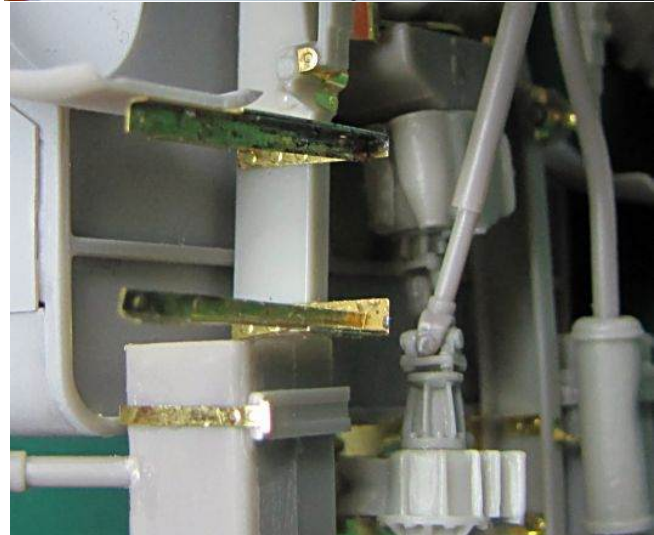
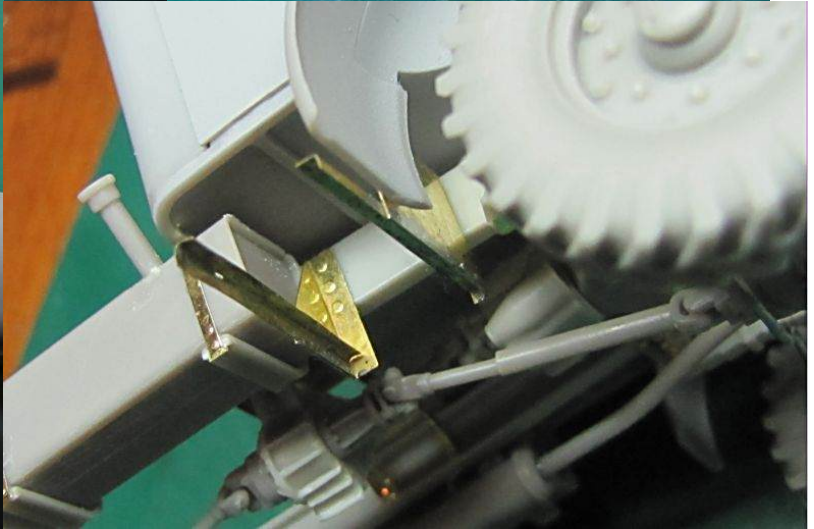
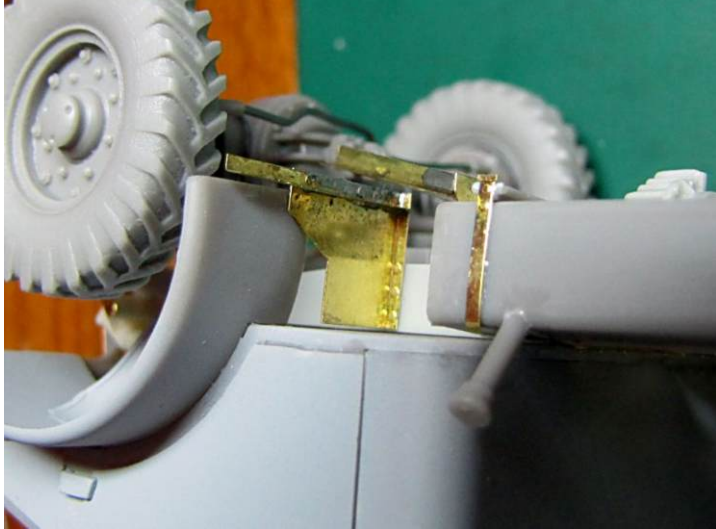
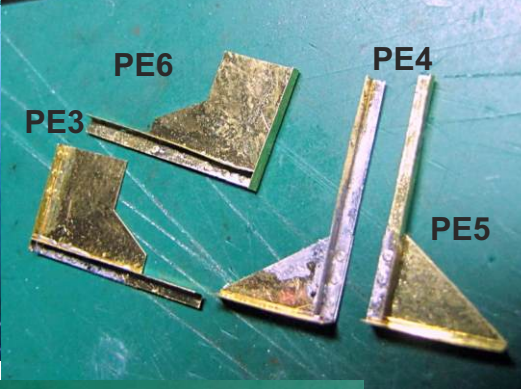
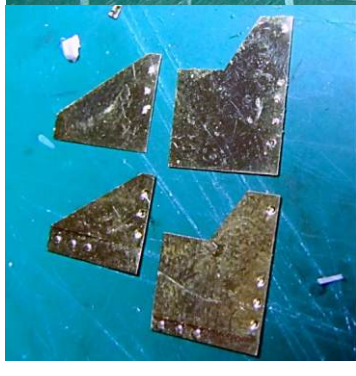
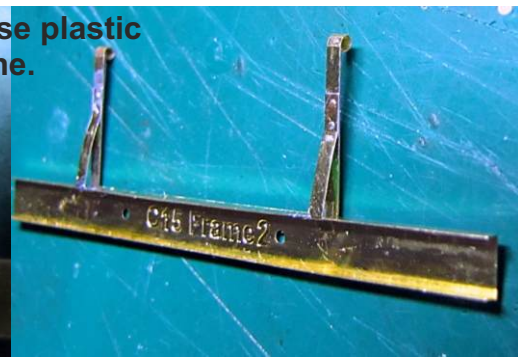
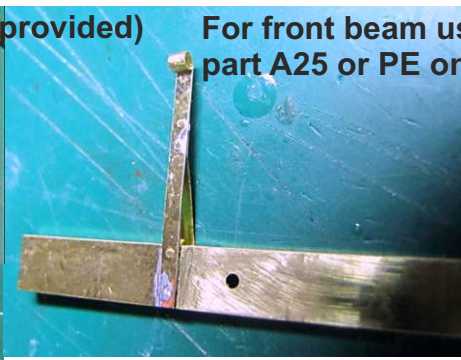
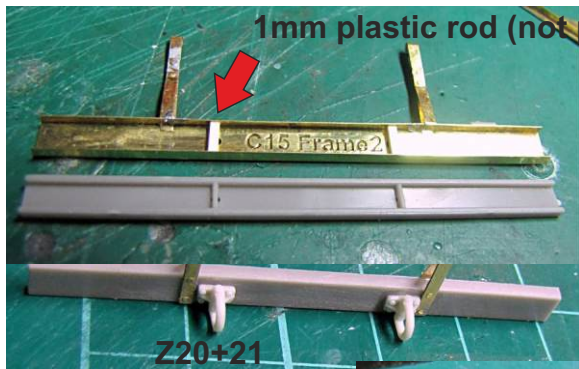

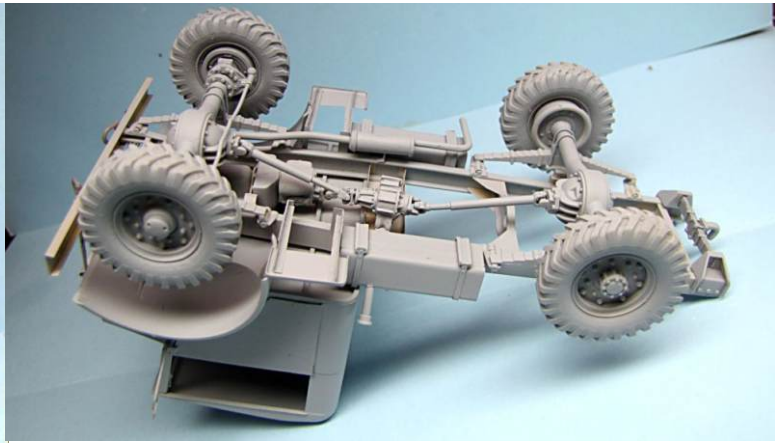
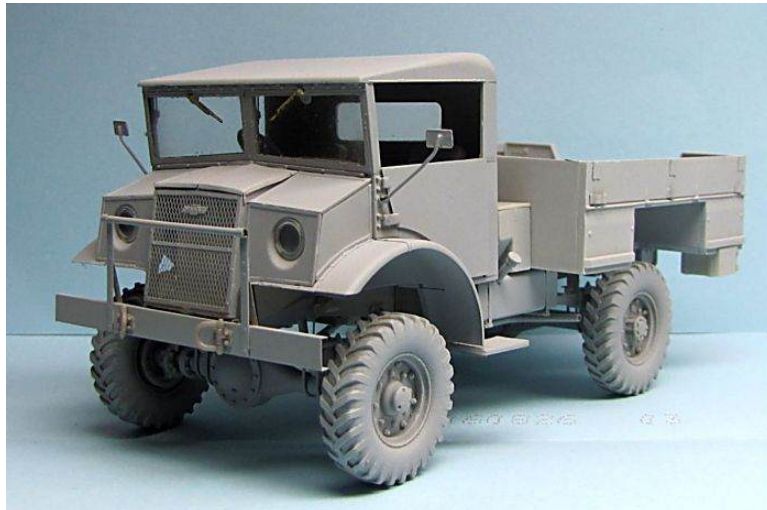

Marking samples, Canadian, British and Italian

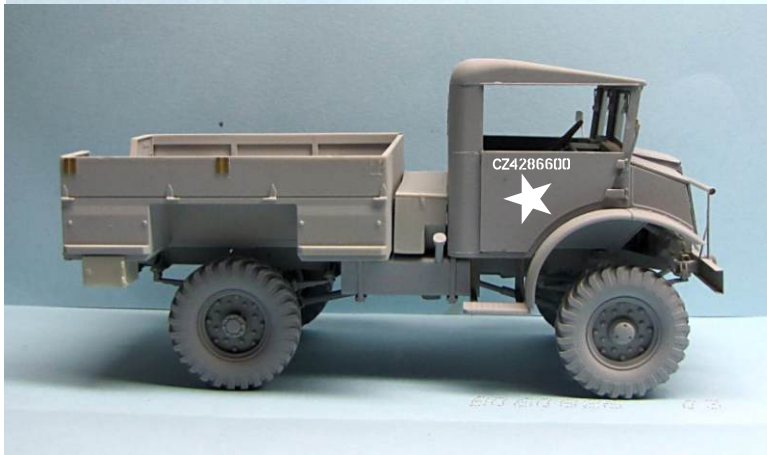

Vehicles often painted in olive drab, or sand yellow if used in desert service

Full photo instructions with part list in colors with hi-res images available to download

www.mirror-models.com

http://mirror-models.com/c15a_cab13_assembly.pdf

Detailing set with windows covers, spare wheel and other details available at www.Lzmodels.com

Conversion set to convert all 4x4 CMP C15A into 2x4 C15 trucks available at www.Lzmodels.com

Water Tank Lorry with Cab13 available at www.Lzmodels.com